



4'&8' AeroSeal LED Vapor Tight Fixture

Description

The **AeroSeal** LED fixture combines a sleek, modern design with robust performance, making it an ideal solution for wet and demanding environments. Designed with a durable polycarbonate housing, **AeroSeal** offers excellent impact resistance while its IP65 rating ensures reliable protection against moisture and dust. Available in 4ft and 8ft lengths, it delivers powerful illumination with energy-efficient LED technology, reducing power consumption without compromising performance. With its compact profile and versatile mounting options, **AeroSeal** is well-suited for parking garages, warehouses, walkways, and other high-moisture areas. This fixture is built to withstand tough conditions while providing efficient and dependable lighting.



Model: ASVT-4 & -8

Optical:

CCT: 3500K -6000K
Lumen Efficacy: 140LM/W
CRI: >82



Electrical:

Rated Power: 30W-35W-40W
Input voltage: 100-277VAC
Beam angle: 116°

Life:

Lumen maintenance: 50,000
Warranty: 2 Years

General:

Dimmable Solution: 0-10V
IP: IP65
Certification: ETL , DLC , FCC listed
Application: Car Washes/Food processing/Gas Station
Laboratories/Industrial
Facilities/Warehouse/Supermarket





4'&8' AeroSeal LED Vapor Tight Fixture

DIMENTION

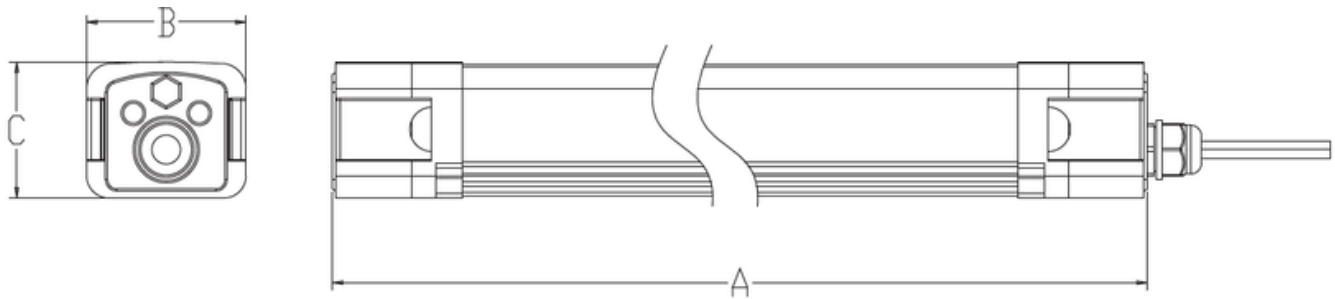

MODEL	SIZE	A (inch)(mm)	B (inch)(mm)	A (inch)(mm)
ASVT-4	4FT	47.24" 1200mm	2.91" 74mm	2.44" 62mm
ASVT-8	8FT	94.45" 2400mm	2.91" 74mm	2.44" 62mm



4'&8' AeroSeal LED Vapor Tight Fixture

SEPICIFICATION

Model	Size	Power	Input Voltage	Dimmable	PF	Light Efficacy	Ra	CCT
ASVT-4	4FT	30/35/40W	AC100-277	0-10V	>0.9	140lm/w	80	35K/4K/5K/6K
ASVT-8	8FT	60/70/80W	AC100-277	0-10V	>0.9	140lm/w	80	35K/4K/5K/6K

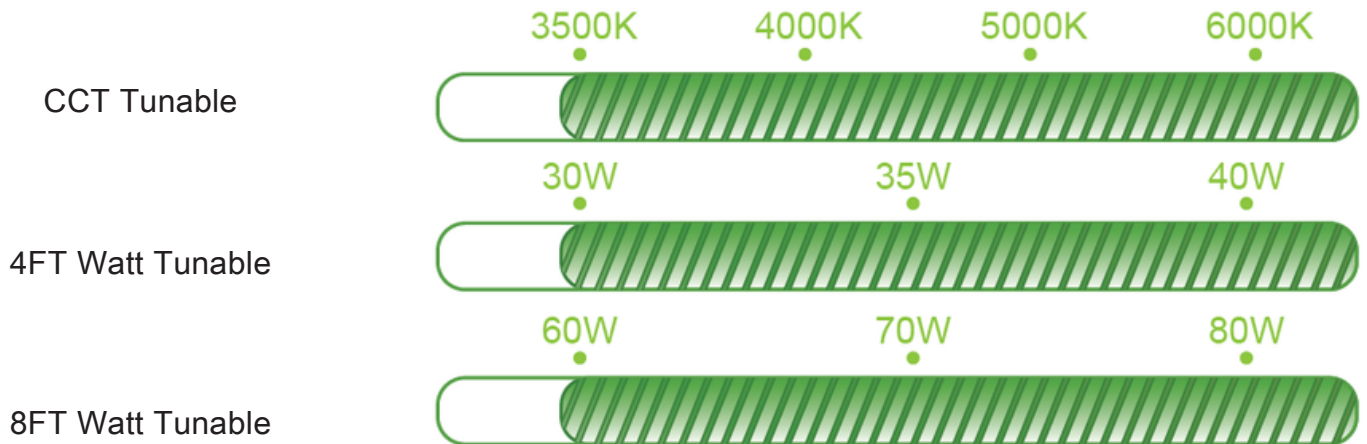



4'&8' AeroSeal LED Vapor Tight Fixture

INSTALLATION

Surface Mounted Installation

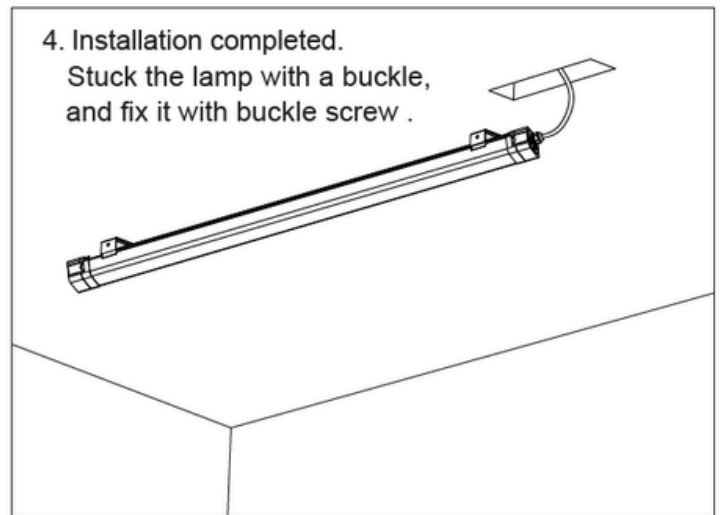
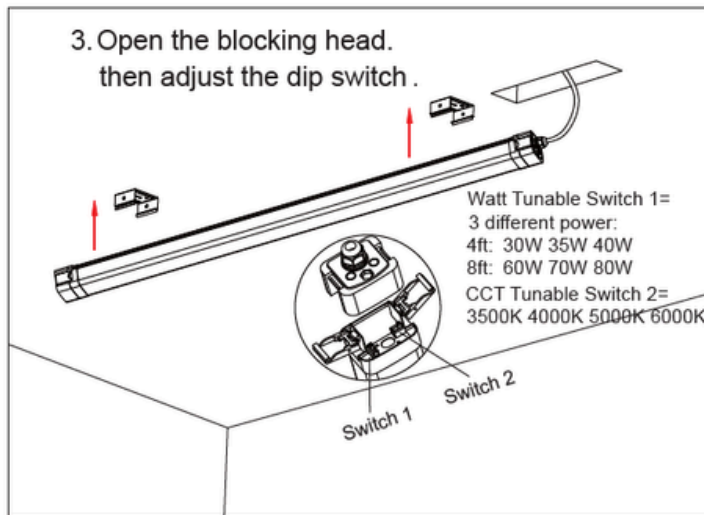
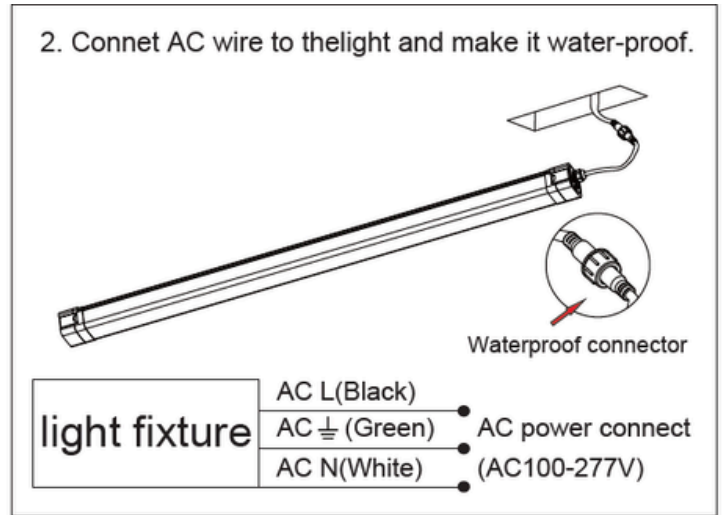
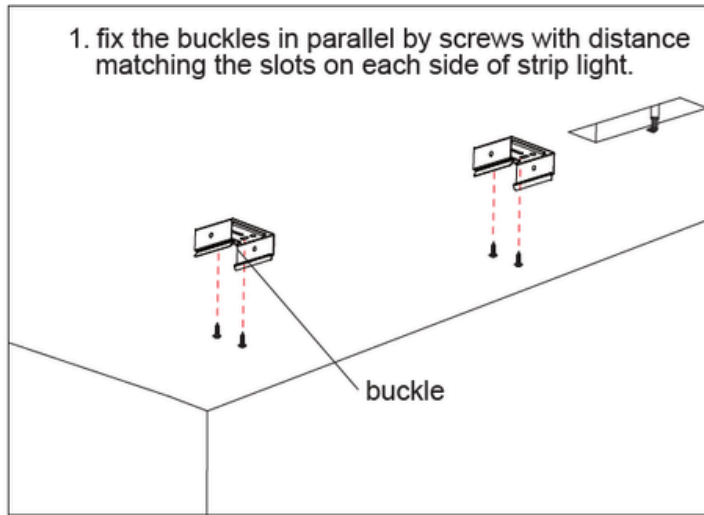



4'&8' AeroSeal LED Vapor Tight Fixture

INSTALLATION

Chain Installation

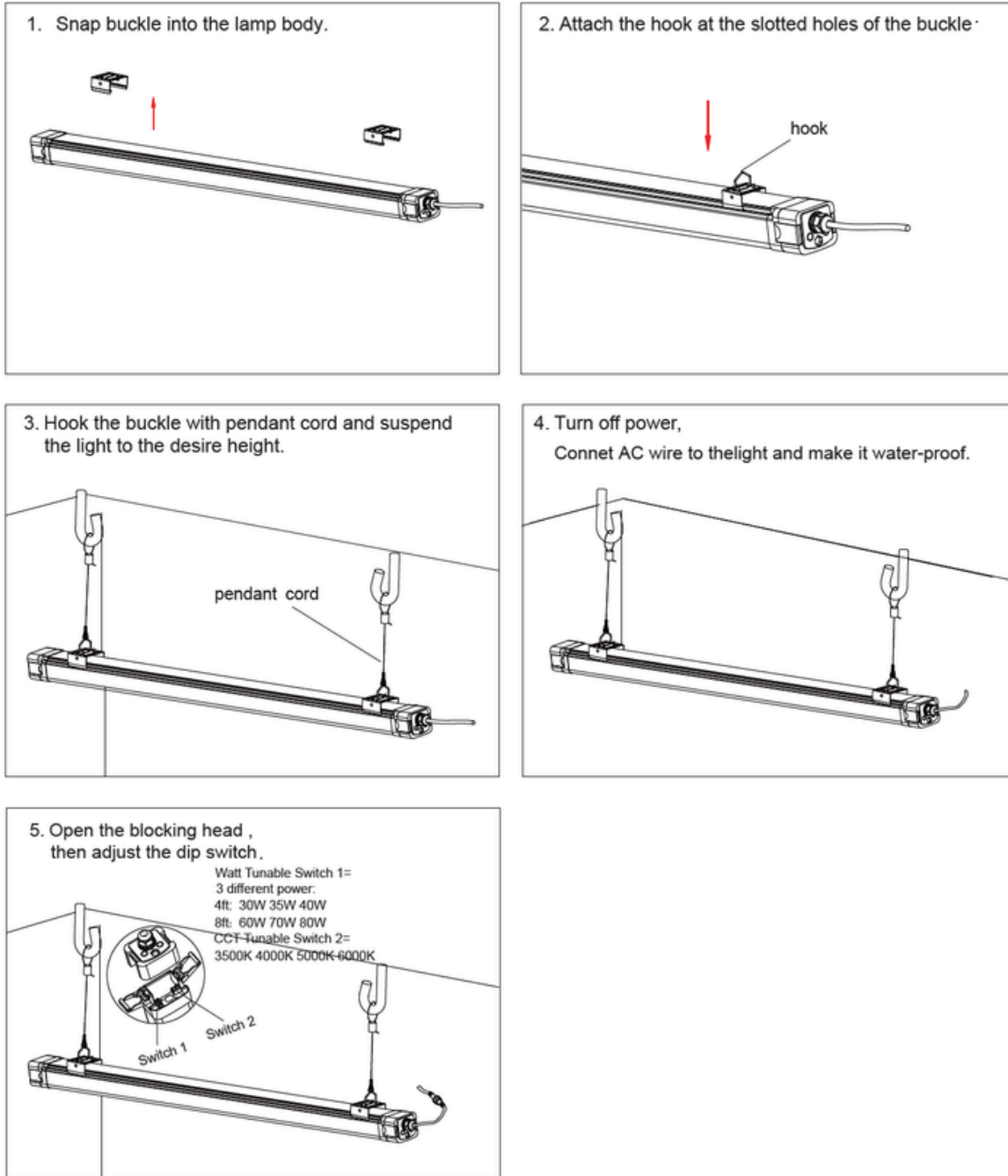



4'&8' AeroSeal LED Vapor Tight Fixture

INSTALLATION

Connection Instruction

1. Open the end cap by pulling the fastener.

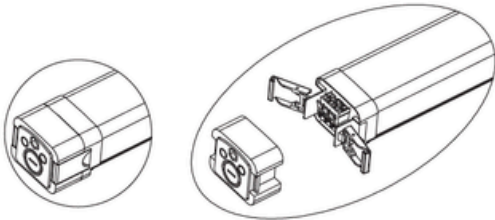

2. Waterproof end cap with connector.

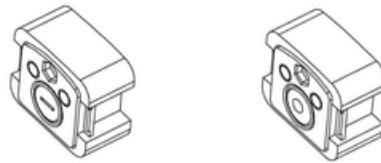

3. Put the AC cable into the waterproof end cap of another Tri-proof light, After wiring, Close the end cap and twist tight the waterproof connector.

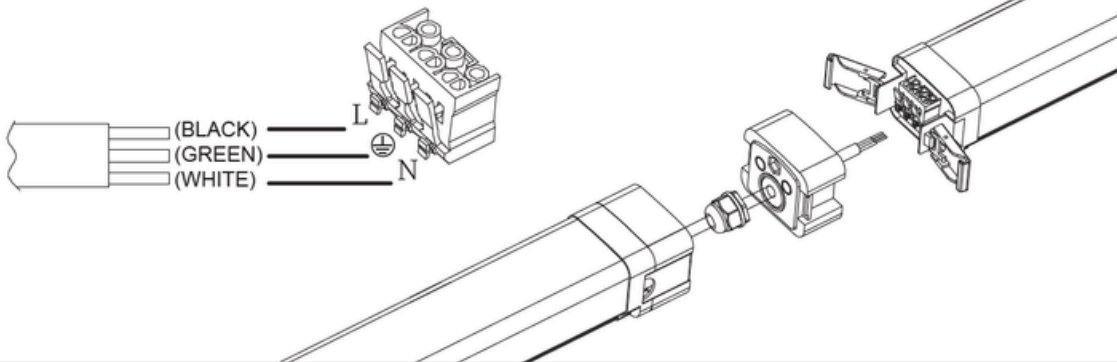

4. Tri-proof light in connection.

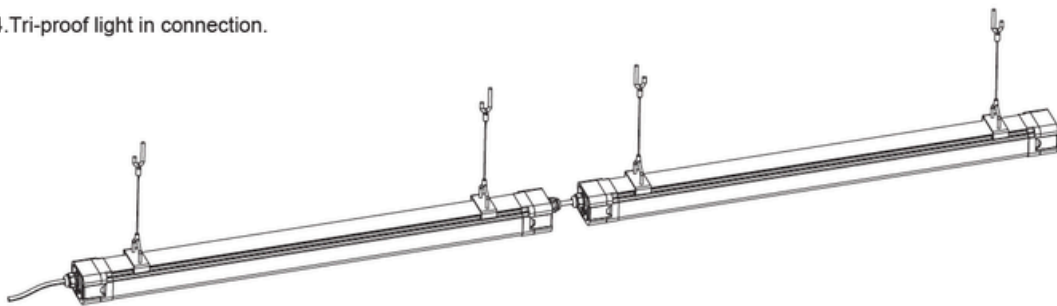



4'&8' AeroSeal LED Vapor Tight Fixture

Distribution Diagram

LED Linear Vapor Light 4FT 30W-35W-40W 3500K-6000K

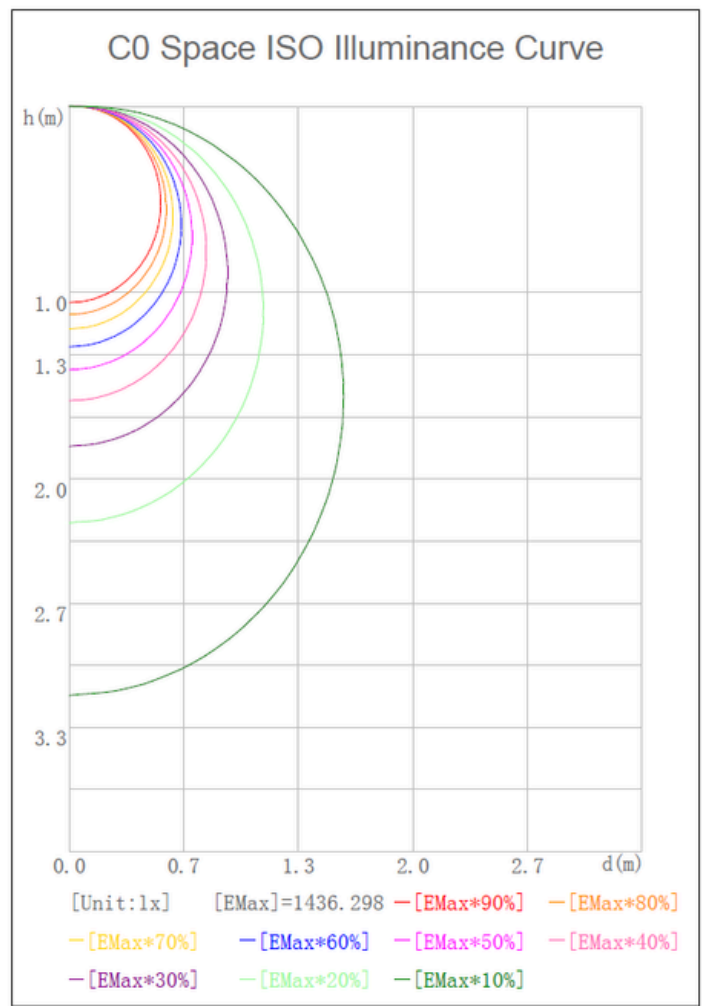
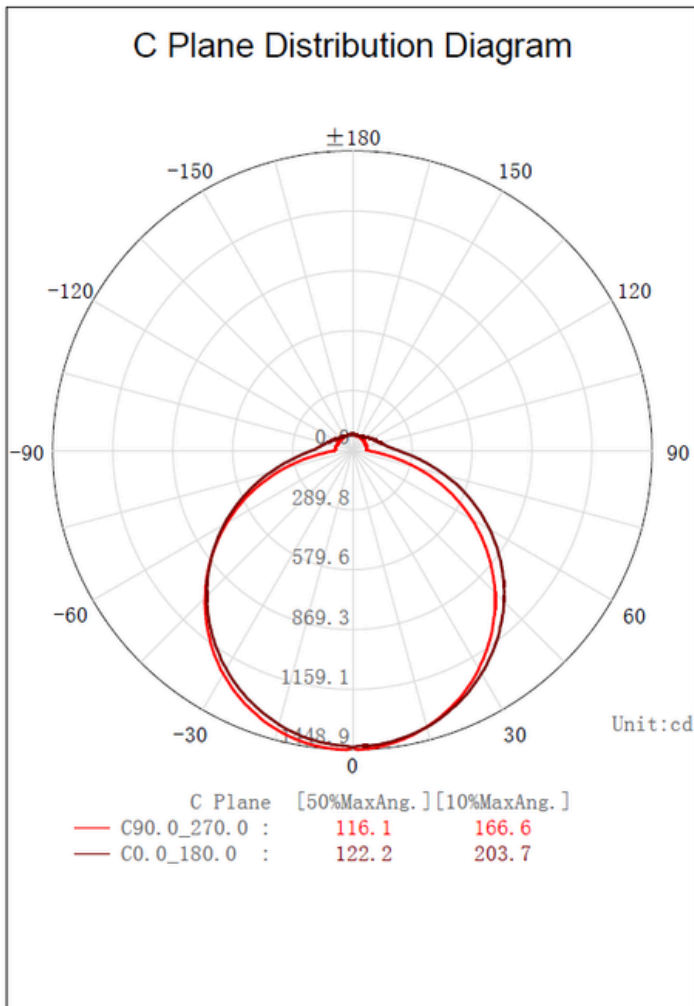



4'&8' AeroSeal LED Vapor Tight Fixture

Distribution Diagram

LED Linear Vapor Light 8FT 60W-70W-80W 3500K-6000K

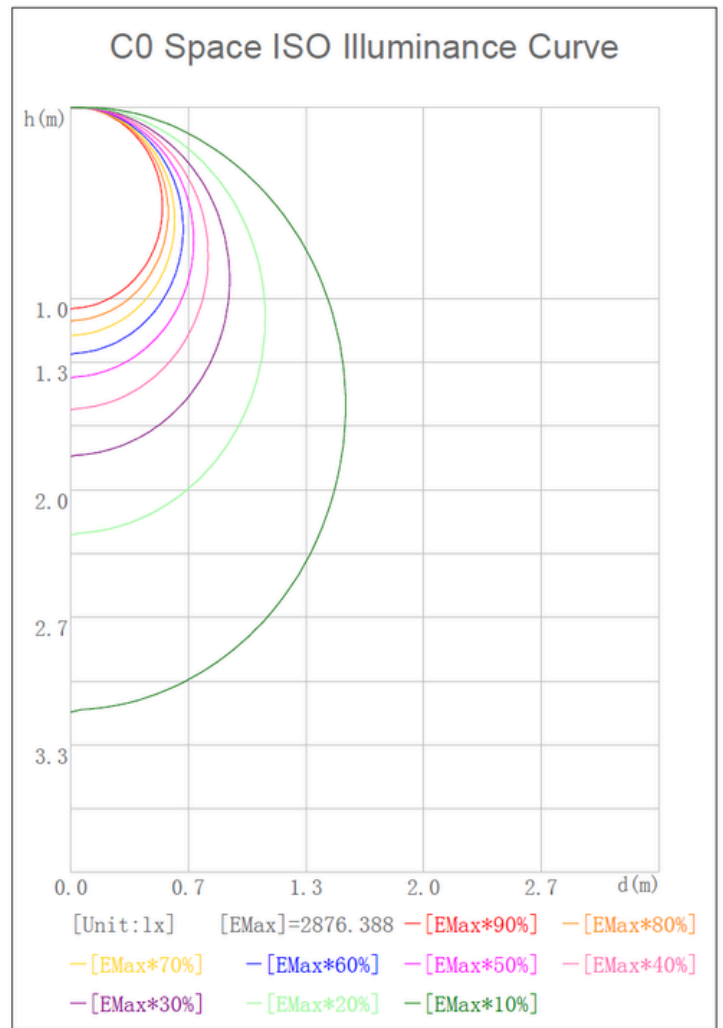
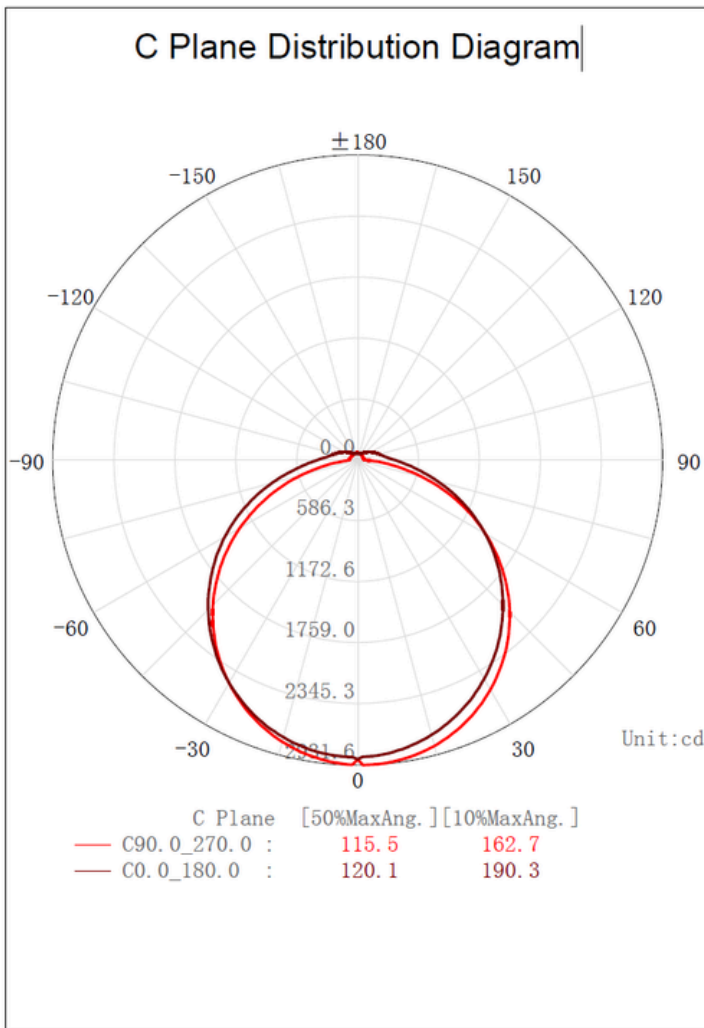



4'&8' AeroSeal LED Vapor Tight Fixture

APPLICATION PICTURE

