



8' LED LINEAR STRIP LIGHT G2



Description:

Introducing a versatile lighting solution for effortless installation and customization. This second-generation design, with a neater look and slimmer size, features an integrated LED system with a snap-lock diffuser lens, ensuring secure and hassle-free assembly. Tailor brightness and tone with adjustable power and color temperature (CCT) to meet specific needs. Options available for this fixture include a microwave motion sensor and battery backup for added versatility.

Model: LRL6511083CG2TO

Optical:

Lumen Efficacy:	130 LM/W
LED Type:	SMD
CRI:	≥80

Electrical:

Input voltage:	120-347V / 50/60HZ
Power	55/60/65 Watt tunable
Beam angle:	110° Dir Light Only
Power factor:	> 0.9

Life:

Lumen maintenance:	50,000h
Warranty:	2 Years

General:

Operating temperature:	20 to 45°C
Finish color Availability:	White
Certification:	UL, CUL, FCC, DLC

Specification:

- UL Listing:
- Suitable for damp locations
- LEDs:
- Long-life, high-efficiency, micro-power LEDs
- Lifespan:
- Lumen Maintenance, L70 > 100,000 hours
- Dimming Driver:
- Driver includes dimming control wiring for 0-10V dimming systems. The dim-to-off voltage threshold of optional 12V AUX integrated driver ranges from 0.1V to 0.5V.
- Housing:
- Sheet metal stamping





LED LINEAR STRIP LIGHT G2

2FT	20W								
	3500K	4000K	5000K						
Lumens	2600	2620	2640						
Efficacy (lm/W)	130	131	132						
3FT	25W								
	3500K	4000K	5000K						
Lumens	3250	3275	3300						
Efficacy (lm/W)	130	131	132						
4FT	30W			35W			45W		
	3500K	4000K	5000K	3500K	4000K	5000K	3500K	4000K	5000K
Lumens	3900	3930	3960	4550	4585	4620	5850	5895	5940
Efficacy (lm/W)	130	131	132	130	131	132	130	131	132
8FT	65W			75W			90W		
	3500K	4000K	5000K	3500K	4000K	5000K	3500K	4000K	5000K
Lumens	8450	8515	8580	9750	9825	9900	11700	11790	11880
Efficacy (lm/W)	130	131	132	130	131	132	130	131	132



Ordering table		Sample : LRLG2-4-40-347-3C-W			
Modle	Lengh	Wattage	Voltage	CCT	Options
LRLG2	2ft :2 3ft :3 4ft: 4 8ft: 8	20W:20 25W:25 28W-32W-40W :40 55W-60W-65W: 65	120-277:UNV 120-347 : 347	3CCT : 3C	Battery : B Sensor : S Wire guard : W



LED LINEAR STRIP LIGHT G2

DIMANSION:

Length:

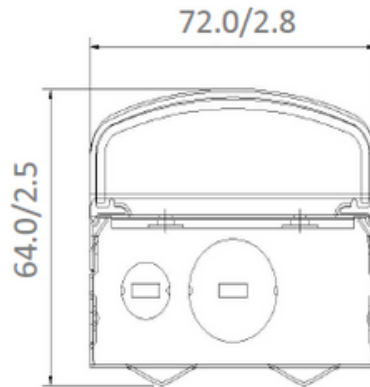
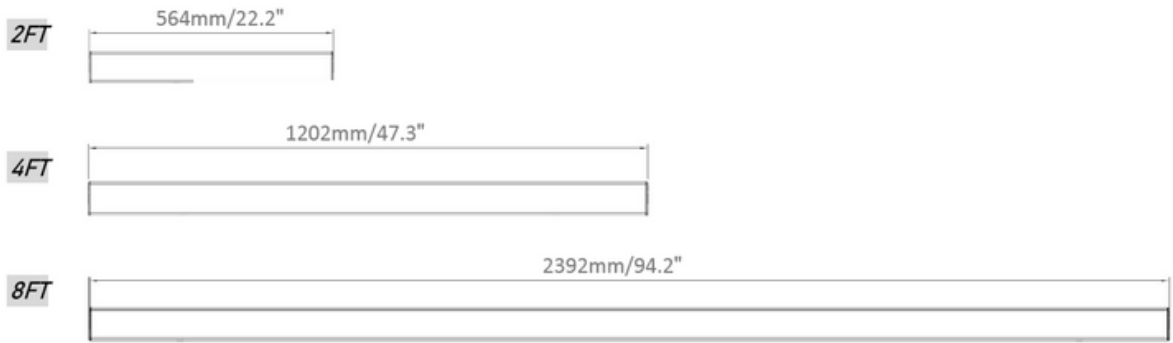

PRODUCT WEIGHT(Kg/lb.)

Product series	2FT	3FT	4FT	8FT
STR2-W	1.20/2.65	1.60/3.53	2.00/4.41	3.85/8.49

