



## PYJD-TDW Series 200W

### TRIAC Dimmable LED Driver - Constant Voltage Output



Class P TYPE HL SELV RoHS



### Features

Output:	Constant Voltage
Range:	110-277VAC
PFC design:	Built-in active PFC function
Efficiency:	Up to 90%
Protections:	Short circuit / Over load / Over temperature
Heat dissipation:	Cooling by free air convection
Waterproof performance:	Driver built in junction box, for dry, damp & wet locations.
Dimming function:	<u>Phase dimming</u> : work with Forward phase, MLV and Reverse phase, ELV, TRIAC dimmers.
Dimming range:	0.1-100%
Application:	Suitable for the application of LED lighting
Warranty:	2 years warranty
Others:	PWM output, High power factor PF>0.9, flicker-free dimming



## TRIAC Dimmable LED Driver - Constant Voltage Output

### Specification

Model		PYJD-12200-TDW	PYJD-24200-TDW	PYJD-48200-TDW
Certificate		(12V/24V): UL / cUL / FCC / Class P / TYPE HL / SELV / ROHS / REACH (48V): /		
Output	DC Voltage	12V	24V	48V
	Voltage Tolerance	±0.5V		±1V
	Voltage Regulation	±0.5%		
	Rated current	16.6A	8.33A	4.17A
	Rated power	200W		
	Load Regulation	±2%	±1%	±1%
Input	Voltage Range	110-277VAC		
	Frequency Range	50 / 60Hz		
	Power Factor @ full load	>0.9		
	THD(Typ.) @ full load	<20%@120VAC & 277VAC		
	Efficiency(Typ.) @ full load	≥86%@120VAC	≥88%@120VAC	≥88%@120VAC
		≥88%@277VAC	≥90%@277VAC	≥90%@277VAC
	AC Current (Max.)	2.3A		
	Inrush Current (Typ.)	40A, 570us@50%120VAC    65.6A, 560us@50%277VAC		
Leakage current	<0.5mA			
Protection	Short Circuit	12V/24V: Shut down o/p voltage, re-power on to recover after fault condition removed. Or, hiccup mode, recovers automatically after fault condition is removed. 48V: Hiccup mode, recovers automatically after fault condition is removed.		
	Over Load	105%~120% 12V/24V: Shut down o/p voltage, re-power on to recover after fault condition removed. 48V: Hiccup mode, recovers automatically after fault condition is removed.		
	Over temperature	Shell surface temp.100°C±10°C shut down o/p voltage, automatically recover after cooling.		
Environment	Working TEMP.	-40~+60°C (see below derating curve)		
	Working Humidity	20 - 95%RH non-condensing		
	Storage TEM.,Humidity	-40 - +80°C,10 - 95% RH non-condensing		
	TEMP.coefficient	±0.03%/°C(0 - 50°C)		
	Vibration	10~500Hz, 5G 12min./1 cycle, period for 72min. each along X,Y,Z axes		
Safety & EMC	Safety standards	UL8750; CAN/CSA-C22.2 No.250.13		
	Withstand voltage	I/P-O/P: 1.88KVAC I/P-FG: 1.88KVAC O/P-FG:0.5KVAC		
	Isolation resistance	I/P-O/P: 100MΩ/ 500VDC/ 25°C/ 70% RH		
	EMC Immunity	FCC/ICES do not request this test.		
	EMC Emission	FCC Part15 Subpart B; ANSI C63.4-2014		
Others	Net Weight	1.82KG		
	Dimension	260.6*106*49mm (L*W*H)		
	Packing	320*295*240mm 10pcs/CTN		
Notes	<ol style="list-style-type: none"> <li>All parameters NOT specially mentioned are measured at 120VAC input, rated load and 25°Cof ambient temperature.</li> <li>Tolerance: includes set up tolerance and load regulation .</li> </ol>			



---

## TRIAC Dimmable LED Driver - Constant Voltage Output

### MCB recommendation

When the input voltage is 120Vac, the number of LED Driver matched by circuit breakers is as follows:		
MCB Type	Level	The number of LED Driver
C type	10A	4
	13A	5
	16A	6
	20A	8
	25A	9
When the input voltage is 277Vac, the number of LED Driver matched by circuit breakers is as follows:		
MCB Type	Level	The number of LED Driver
C type	10A	3
	13A	4
	16A	5
	20A	6
	25A	7

#### Note:

1. The above quantities of the led drivers connected on the Type C is recommended base on the maximum ambient temperature is 50 °C.
2. The breaker should be selected according to the input rated voltage, input rated current, ambient temperature, and trip characteristic curve.



## TRIAC Dimmable LED Driver - Constant Voltage Output - PYJD-TDW Series 200W

### Efficiency Curve (efficiency vs output load)

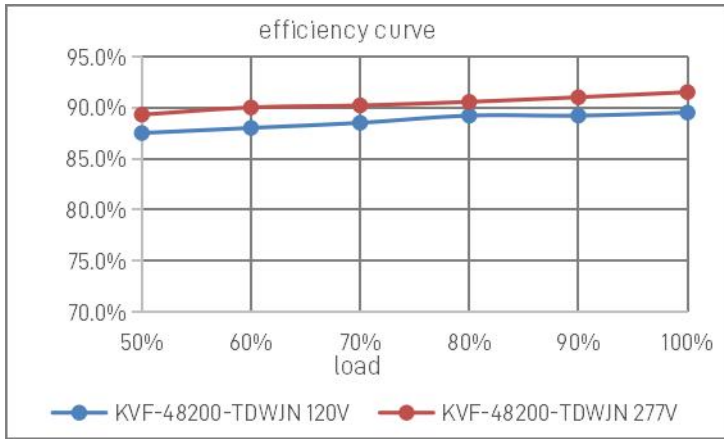
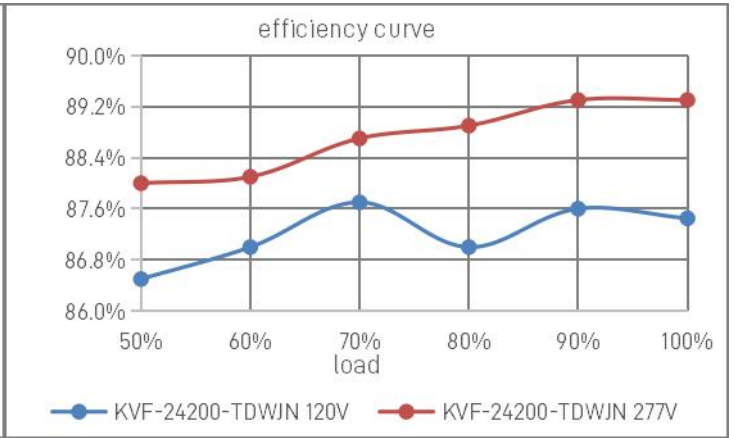
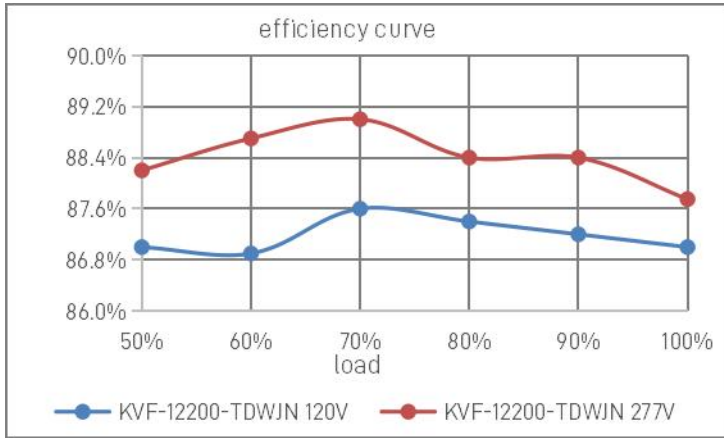



## TRIAC Dimmable LED Driver - Constant Voltage Output - PYJD-TDW Series 200W

### Power Factor Curve (power factor vs output load)

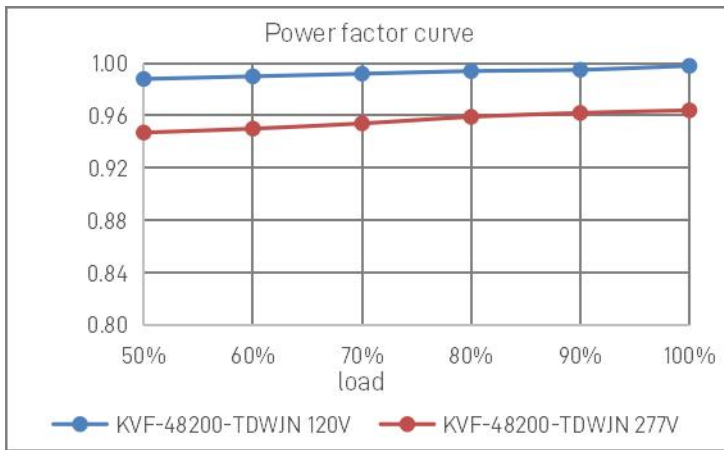
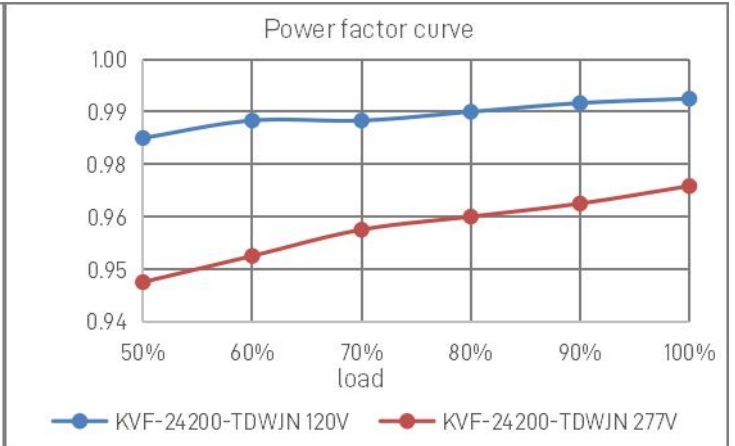
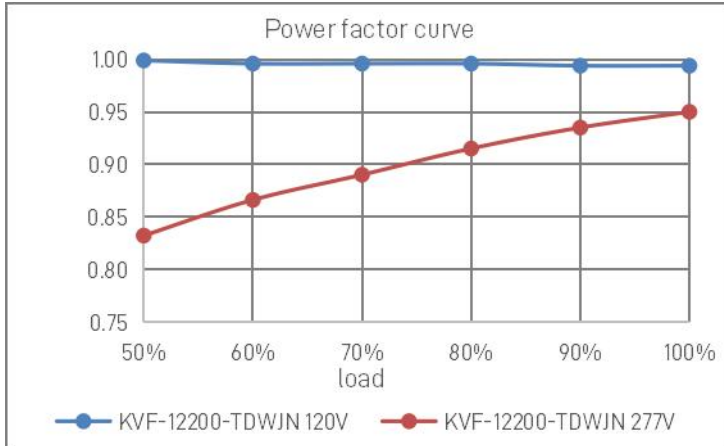

### Derating Curve (output load vs TEMP.)

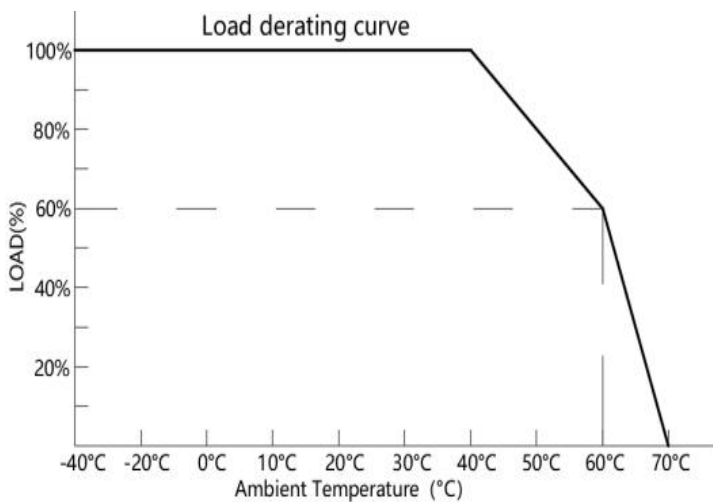

- To extend their life, please refer to the Derating Curve and derate according to the temperature.
- Please note that the rise in temperature of LED fixtures over a long period of time will cause their power to rise. Therefore, we recommend the power supply to reserve a certain amount of load to avoid overloading.



## TRIAC Dimmable LED Driver - Constant Voltage Output - PYJD-TDW Series 200W

### Mechanical Specification

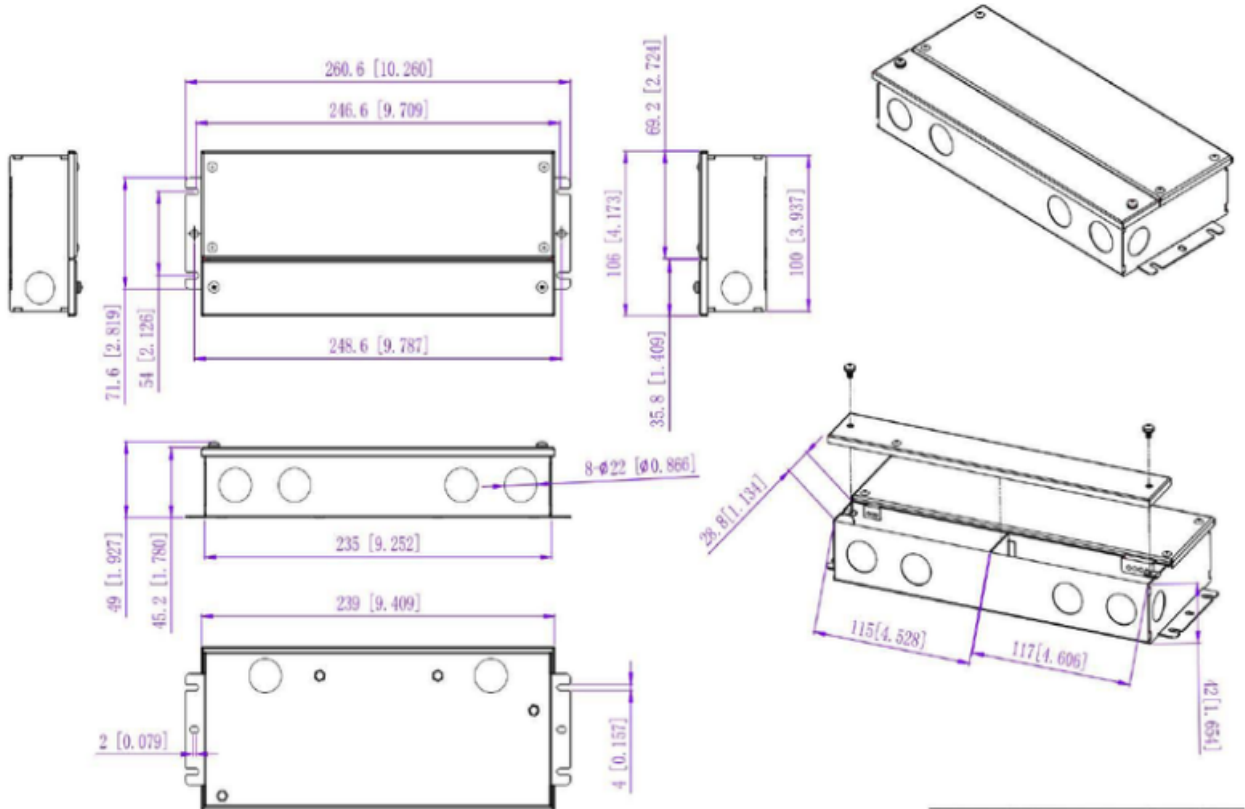

American wire gauge

JM96-A1

Input wire

Black(L) White(N) Green(G)(3\*18AWG)

Output wire

Red(V+) Black(V-)(2\*14AWG)

Remarks: Please make sure you connect these correctly otherwise your product will not function correctly and could be damaged.

### Warm tips:

1. Recommended Max. Carrying Current (A) = wire diameter(mm<sup>2</sup>) x 10A/mm<sup>2</sup>  
For example: 1mm<sup>2</sup> output cable, Recommended Max. Carrying Current (A) = 1mm<sup>2</sup> x 10A/mm<sup>2</sup>=10A



## TRIAC Dimmable LED Driver - Constant Voltage Output - PYJD-TDW Series 200W

### Dimming Operation and Connecting Diagram

#### Using one dimming ---TRIAC/Phase cut dimming

1. The Pulse-Width Modulation (PWM) of output voltage can be adjusted through input terminal of the AC phase line(L) by connection a phase /Triac dimmer or lighting system.
2. Working with Forward phase, MLV and Reverse phase, ELV, TRIAC dimmers.
3. Min. loading is about 10%.
4. Please try to use dimmers with power at least 1.5 times as the output power of the driver.

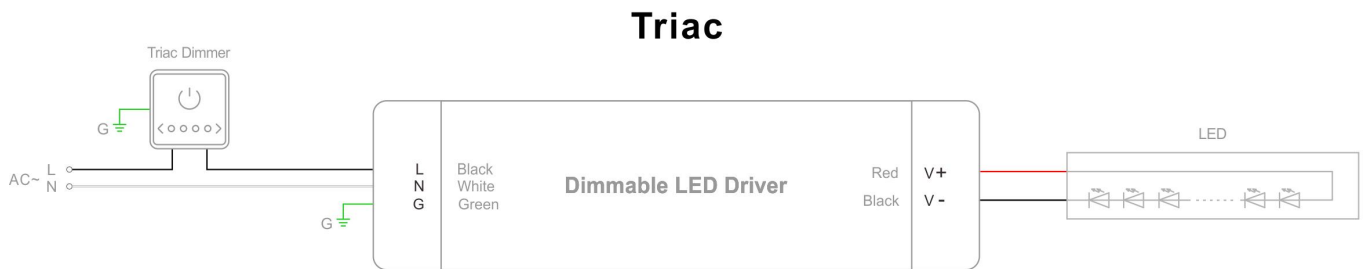

#### Instructions

1. This driver should be installed by qualified and professional person.
2. Please make sure the driver is installed with adequate ventilation around it to allow for heat dissipation.
3. Ensure that wiring is correct before test in order to avoid light and power supply damage.
4. If driver Cannot work normally, don't maintain privately.