

## PYSD - Series 100W

12V/ 24VDC - 100W

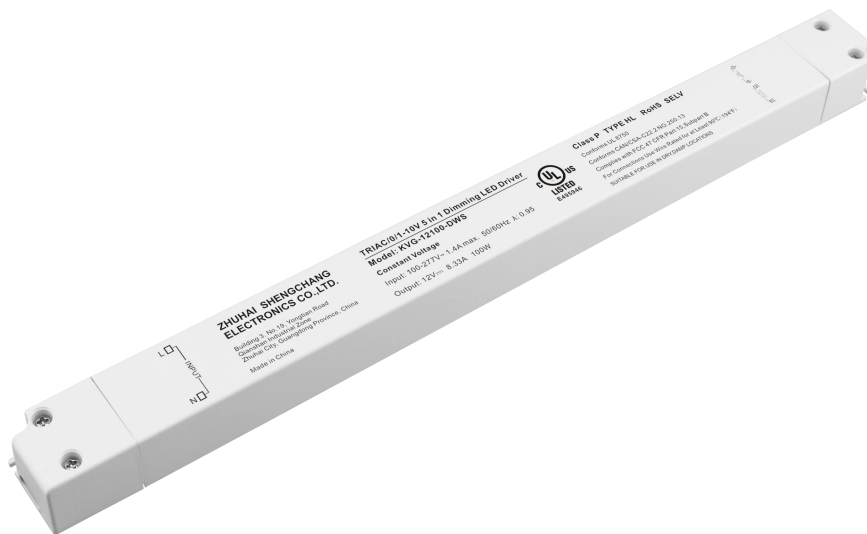

Class P TYPE HL SELV CE RoHS



### Features

Output:	Constant Voltage
Range:	100-277VAC
PFC design:	Built-in active PFC function
Efficiency:	Up to 88%
Protections:	Short circuit/ over load/ over temperature
Heat dissipation:	Cooling by free air convection
Waterproof performance:	Full protection plastic housing, for dry, damp location
Dimming function:	<u>Phase dimming</u> : work with Forward phase, MLV and Reverse phase, ELV, TRIAC dimmers <u>0-10V dimming</u> : 0-10V/1-10V/Potentiometer/10V PWM 4 in 1
Dimming range:	0-100%
Application:	Suitable for LED lighting and moving sign applications
Warranty:	3 years warranty

## Specification

Model		PYSD-12100-DWS		PYSD-24100-DWS			
Certificate		UL / cUL / FCC / CE / ROHS / Reach					
Output	DC Voltage	12V		24V			
	Voltage Tolerance	±0.5V					
	Voltage Regulation	±0.5%					
	Rated current	8.33A		4.16A			
	Rated power	100W					
	Load Regulation	±2%		±1%			
Input	Voltage Range	100-277VAC					
	Frequency Range	47 - 63Hz					
	Power Factor @ full load	0.995@120VAC		0.995@277VAC			
	THD(Typ.) @ full load	<10%@120VAC		<15%@277VAC			
	Efficiency @ full load	82%@120VAC		86%@277VAC		85%@120VAC 88%@277VAC	
	AC Current (Max.)	1.3A					
	Inrush Current (Typ.)	11A ,1.04ms@120VAC		27A ,960us@277VAC			
	Leakage current	<0.5mA					
Protection	Short Circuit	Shut down o/p voltage, recovers automatically after fault condition is removed					
	Over Load	≤120% Hiccup mode, recovers automatically after fault condition is removed					
	Over temperature	Shell surface temp.100°C±10°C shut down o/p voltage, automatically recover after cooling					
Environment	Working TEMP.	-40~+60°C (see below derating curve)					
	Working Humidity	20 - 90%RH non-condensing					
	Storage TEM.,Humidity	-40 - +80°C ,10 - 95% RH non-condensing					
	TEMP.coefficient	±0.03%/°C(0 - 50°C)					
	Vibration	10~500Hz, 2G 10min./1 cycle, period for 60min. each along X,Y,Z axes					
Safety & EMC	Safety standards	UL8750 CAN/CSA-C22.2 No.250.13(US)					
	Withstand voltage	I/P-O/P:1.8KVAC(US)					
	Isolation resistance	I/P-O/P:100MΩ / 500VDC / 25°C / 70% RH					
	EMC Emission	FCC 47 CFR Part 15 ,Subpart B(US)					
Others	Net Weight	0.32Kg					
	Dimension	329.7*30*22mm(L*W*H)					
	Packing	350*330*145mm		50pcs /CTN 17.5KG/CTN			
Notes	<p>1. All parameters NOT specially mentioned are measured at 120VAC input, rated load and 25°C of ambient temperature.</p> <p>2. Tolerance: includes set up tolerance and load regulation .</p>						

### Efficiency Curve (efficiency vs output load)

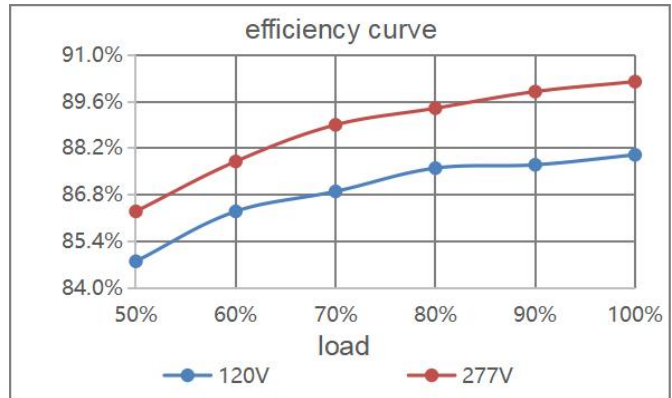
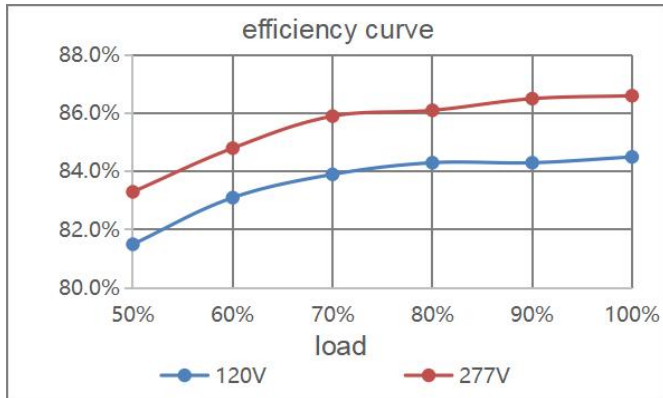

### Derating Curve (output load vs TEMP.)

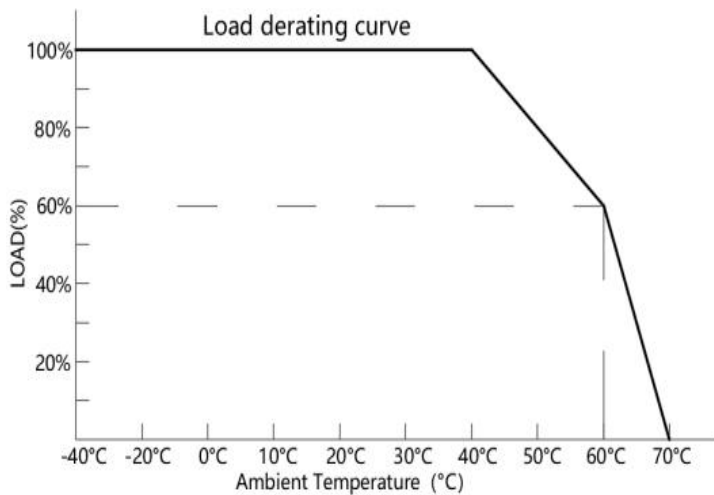

1. To extend their life, please refer to the Derating Curve and derate according to the temperature.
2. Please note that the rise in temperature of LED fixtures over a long period of time will cause their power to rise. Therefore, we recommend the power supply to reserve a certain amount of load to avoid overloading.

### Power factor curve

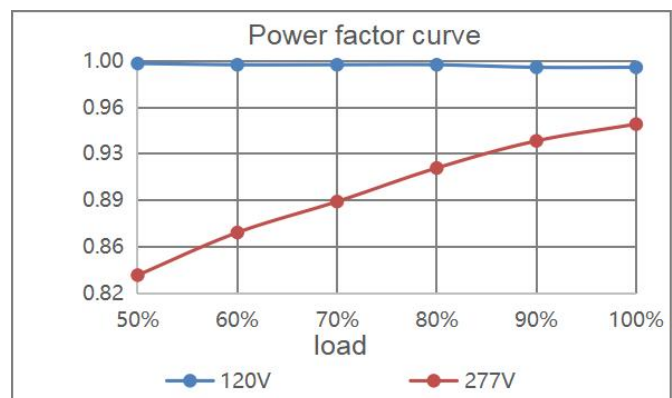
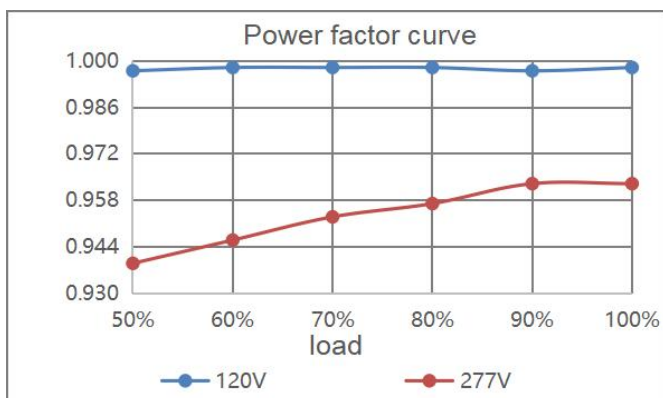

## Mechanical Specification

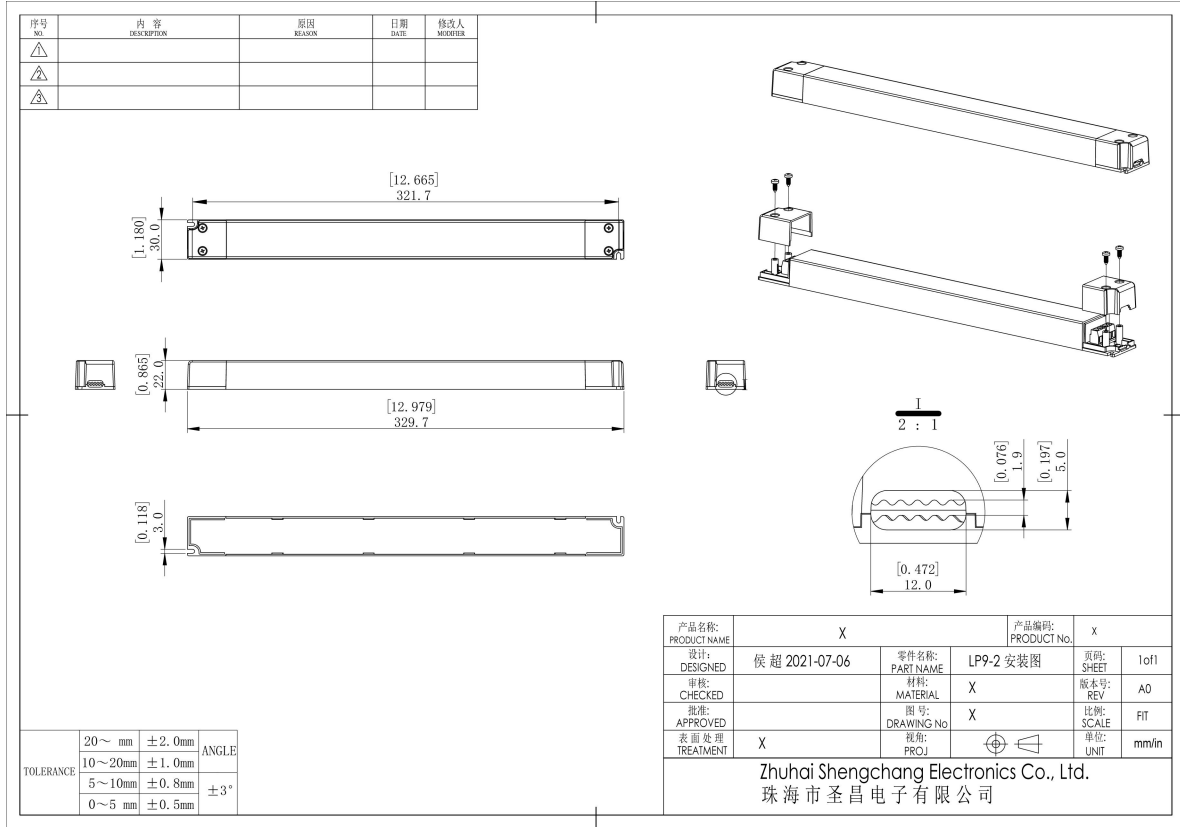

### 12V&24V Version

1. Connect Live and Neutral wire to PRI (L) and (N) of power supply terminals.
2. Connect LED light to SEC Positive (LED+) and Negative (LED-) of power supply terminals.
3. Connect the dimming signal wire (+) and (-) to DIM (+) and DIM(-) of power supply terminals.
4. Please DO NOT connect "DIM-" to "LED-", "DIM+" to "LED+", or other incorrect connection.
5. Please make sure you connect these correctly otherwise your product will not function correctly and could be damaged.

#### Warm tips:

1. Suggested wire diameter: Input 0.75-2mm<sup>2</sup>; Output:0.5-2mm<sup>2</sup>.
2. Any other requests for, we can customized.

## Dimming Operation and Connecting Diagram

- **Using two ways of dimming at the same time**, you must be assured that LED lighting is up to the max. Brightness then you could operate with the other dimming;

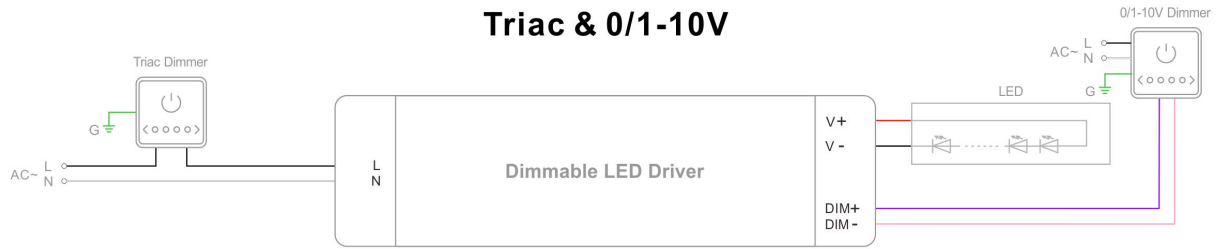

- **Using one dimming ---TRIAC/Phase cut dimming**

1. The Pulse-Width Modulation (PWM) of output voltage can be adjusted through input terminal of the AC phase line(L) by connection a phase /Triac dimmer or lighting system.
2. Working with Forward phase, MLV and Reverse phase, ELV, TRIAC dimmers or light system.
3. Min. loading is about 10%.
4. Please try to use dimmers with power at least 1.5 times as the output power of the driver.

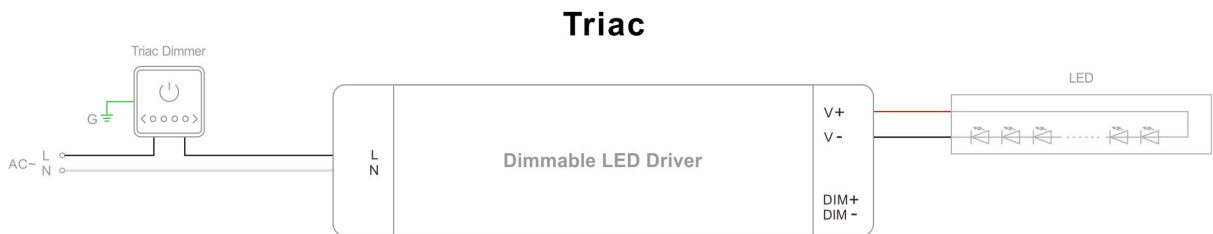

- **Using one dimming ---0-10/ 1-10V/ 10V PWM/ Potentiometer dimming**

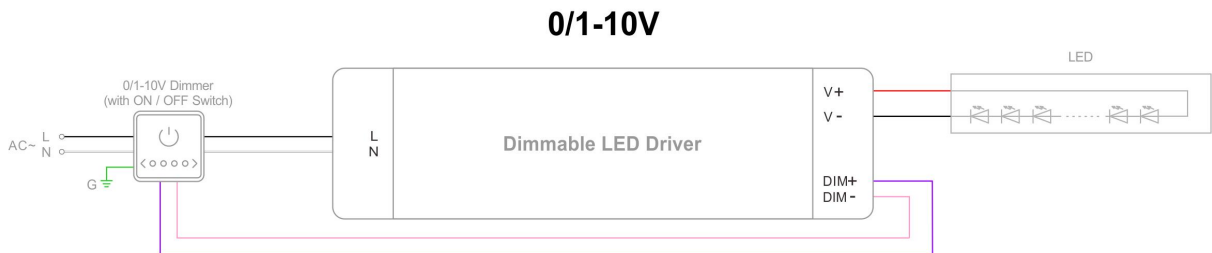

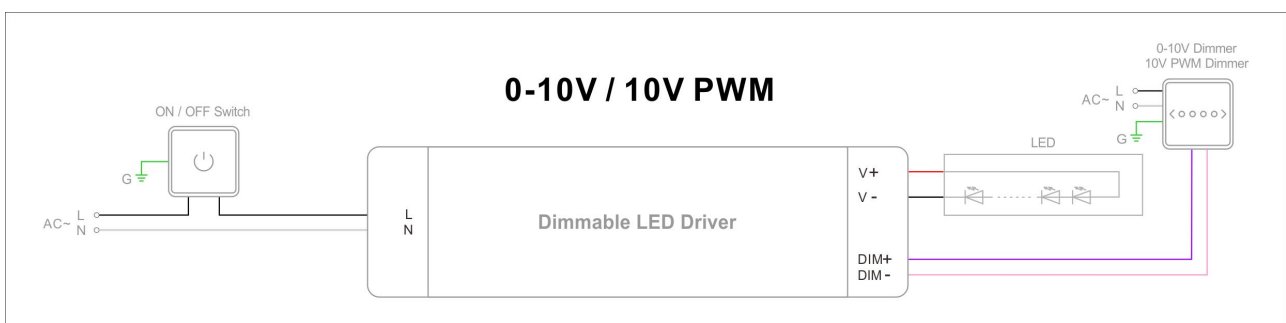
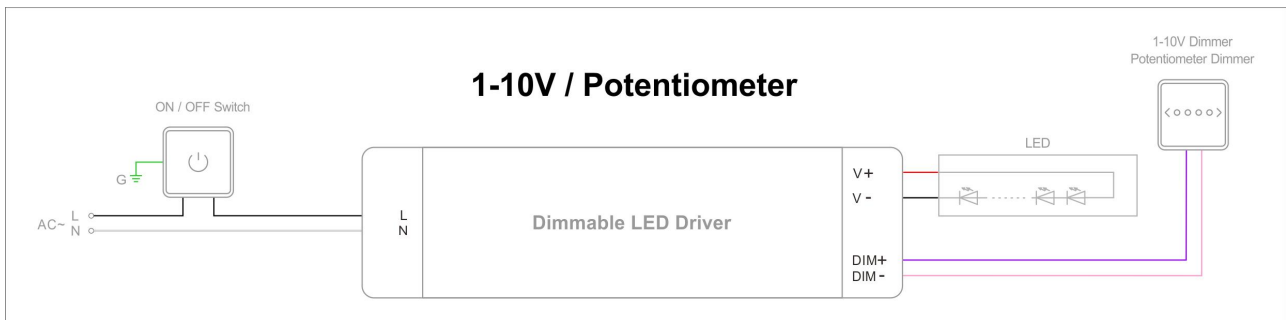

## Instruction

1. This driver should be installed by qualified and professional person.
2. Please make sure the driver is installed with adequate ventilation around it to allow for heat dissipation.
3. Ensure that wiring is correct before test in order to avoid light and power supply damage.
4. If driver Cannot work normally, don't maintain privately.

Have any questions, please contact Zhuhai Shengchang.

Please visit our website or contact us for more information! [www.scpower.net.cn/en](http://www.scpower.net.cn/en)