



**RECESSED LED STAIR LIGHT & WALL LIGHT**

**Description:**

The concrete pour step/wall light offers a sleek and contemporary lighting solution for concrete structures, retaining walls, steps, and stairs. With its low trim profile, it blends seamlessly with the surrounding surfaces. This fixture is highly popular due to its decent power and lumens output. Its easy installation and low maintenance make it a practical choice. The concrete pour step/wall light enhances the ambiance and safety of outdoor spaces effortlessly, adding a stylish touch to any environment.



**Model:** SPL070424003GRKP

**Optical:**

CCT:	3000K
Light source:	7 X 0.5W
Luminance:	CW=85 WW=82
LED Type:	SMD 3030
CRI:	>80

**Electrical:**

Rated Power:	3.5W
Input voltage:	DC 24V
Operating current (MA):	24V=150
LED driver:	Constant Voltage Input, Constant Current Output

**Life:**

Lumen maintenance:	50,000 Hrs
Warranty:	2 YEARS

**General:**

IK:	10
IP:	IP65
Finish color Availability:	Dark Grey
Certification:	cETLus
Operating Temperature:	-20°C~40°C
Dimmable Support	Triac PWM 1-10V Dali



**TRIAC PWM 1-10V DALI**





## RECESSED LED STAIR LIGHT & WALL LIGHT

### DIMENSIONS

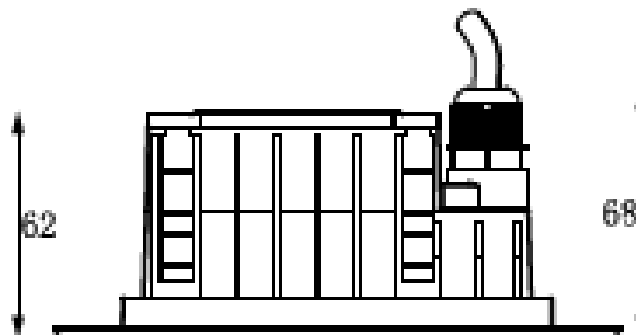
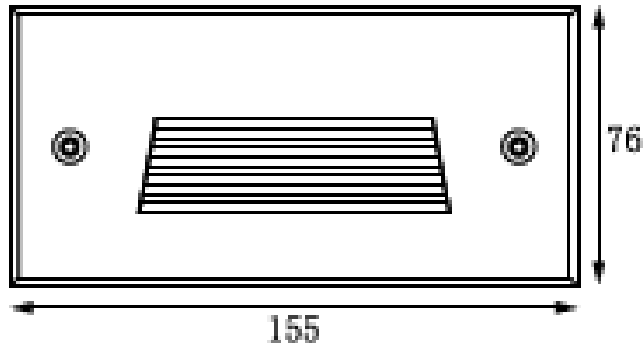
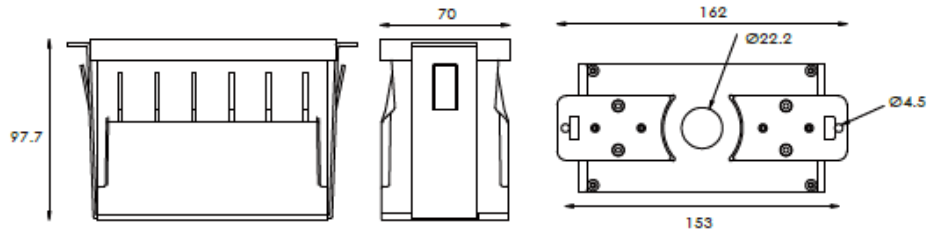



**RECESSED LED STAIR LIGHT & WALL LIGHT**

**PHOTOMETRIC:**

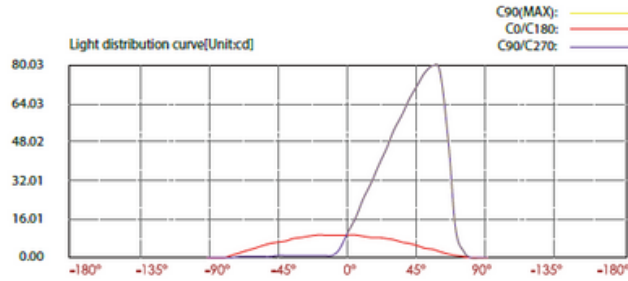
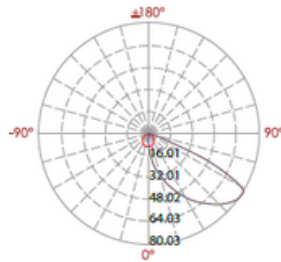

Lux distance curve

Center beam LUX	Illuminance at a distance	
	Beam width V	Beam width H
2m 2.33 LUX	1.7m	3.70m
4m 0.58 LUX	3.3m	7.40m
6m 0.26 LUX	5.0m	11.1m
8m 0.15 LUX	6.6m	14.8m
10m 0.09 LUX	8.3m	18.5m
12m 0.06 LUX	9.9m	22.2m

Ver.Spread:44.9 Horiz.Spread:85.7

