



Lumi Path Surface mounted Ground / Wall Light

Description:

Introducing the Lumi Path Surface-Mounted Ground Light: a versatile and durable lighting solution for pathways, driveways, stairs, retaining walls, and more. Crafted with 316 stainless steel trims and an anodized aluminum housing, this light ensures exceptional durability and strength against varying temperatures. Designed for easy and safe installation, it operates on a 24 VDC input, eliminating the need for rough-in boxes before concrete pouring. Suitable for concrete, wood, or drywall structures, the Lumi Path light offers both directional and non-directional options, making it an ideal choice for enhancing outdoor and indoor spaces.

Model: WLLU21TRC2PY



Optical:

CCT:	3000K
Lumen Efficacy:	240Lm Light source
LED Type:	6PCS SMD
CRI:	Ra>80

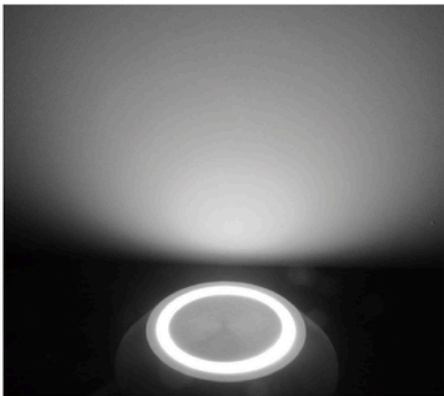

Electrical:

Rated Power:	3W
Input voltage:	24V

Life:

Lumen maintenance:	50000Hrs
Warranty:	2 Years



General:

IP:	IP67
IK:	IK10
Housing Material:	Solid Passivated (Anodizing) Aluminum CNC machined
Trim Material:	Stainless steel 316+PMMA



Lumi Path Surface / mounted /Grand / Wall

Dimension

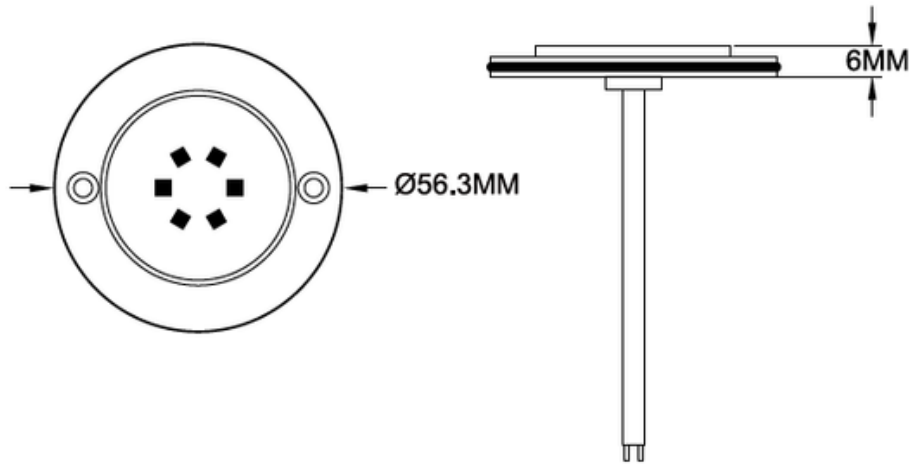



Lumi Path Surface / mounted / Grand / Wall

Dimension

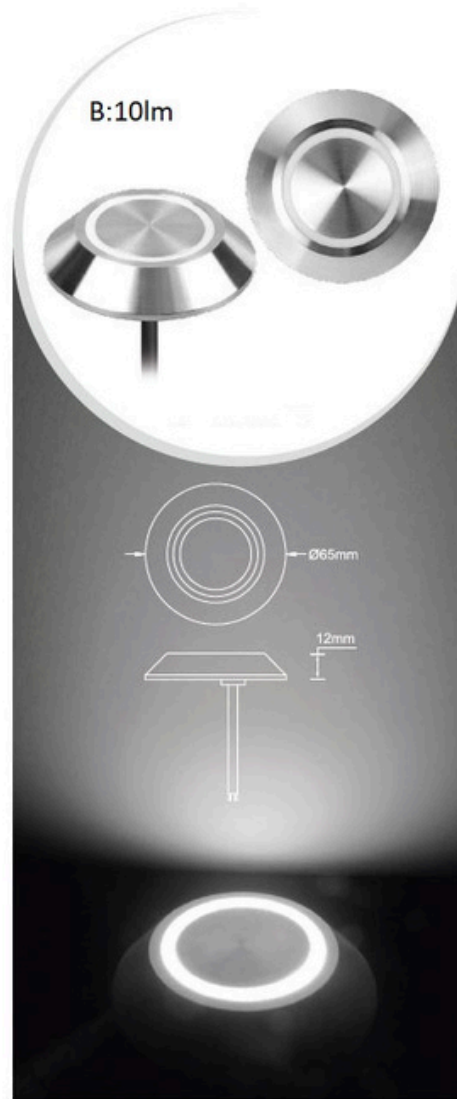
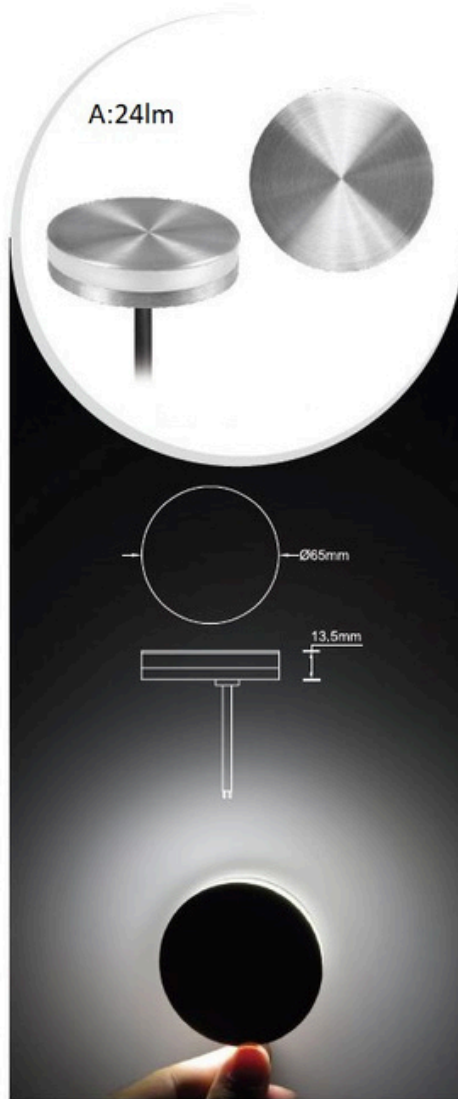



Lumi Path Surface / mounted /Grand / Wall

Dimension

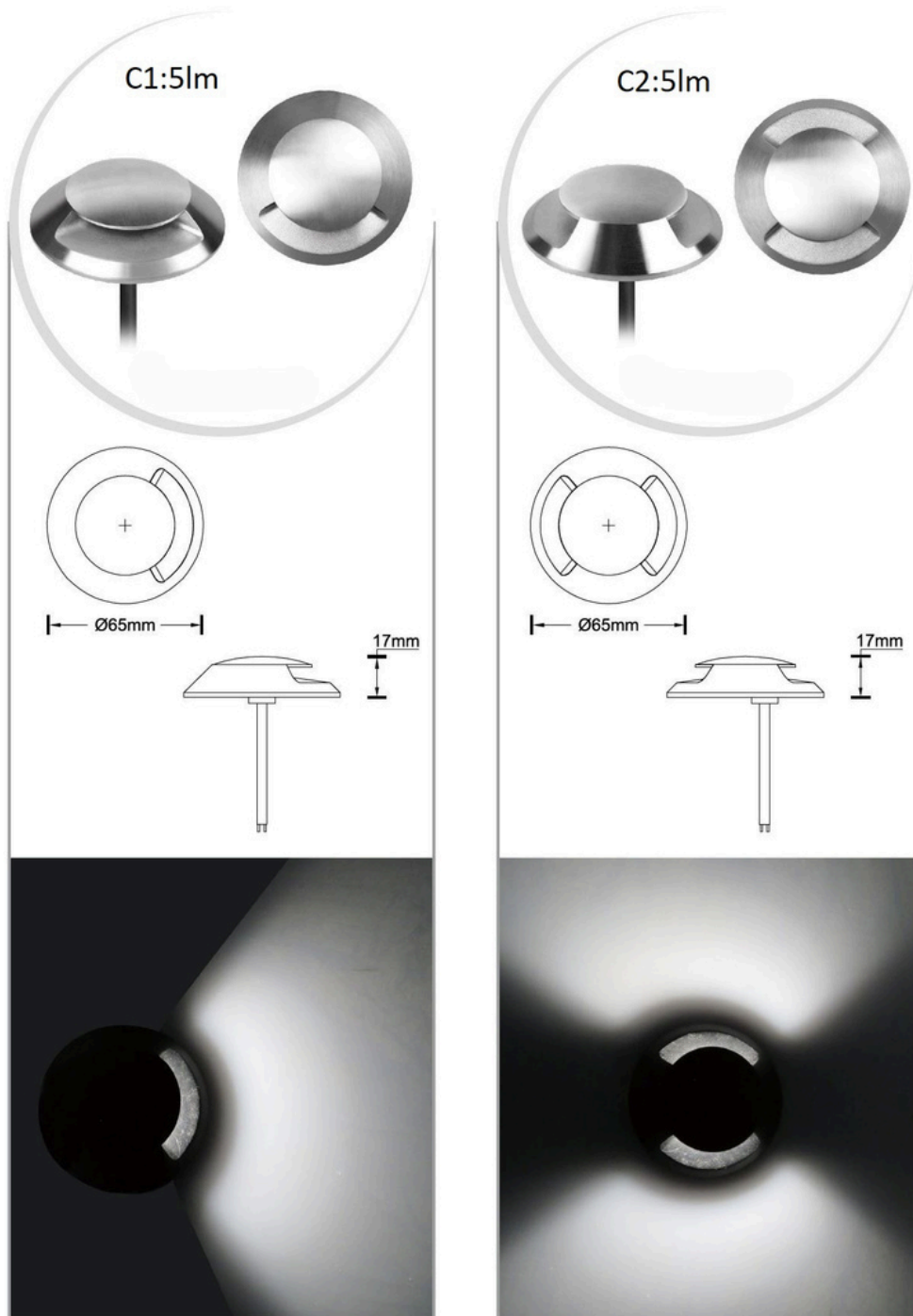



Lumi Path Surface / mounted / Grand / Wall

Dimension

