



LuminaCast Diffuse Concrete Step Light



Description:

The concrete pour step/wall light offers a sleek and contemporary lighting solution for concrete structures, retaining walls, steps, and stairs. With its low trim profile, it blends seamlessly with the surrounding surfaces. This fixture is highly popular due to its decent power and lumens output. Its easy installation and low maintenance make it a practical choice. The concrete pour step/wall light enhances the ambiance and safety of outdoor spaces effortlessly, adding a stylish touch to any environment.

Model: SPL10140324003KKP

Optical:

CCT:	3000
Light source:	L0180C010AR
Luminance:	CW=34 WW=35
LED Type:	SMD
CRI:	>80



Electrical:

Rated Power:	24V=2.4W
Input voltage:	24VDC
Lens degree:	120°
Operating current (MA):	24V=114
LED driver:	Constant Voltage Input, Constant Current Output

Life:

Lumen maintenance:	50,000 Hrs
Warranty:	2 YEARS

General:

IK:	09
IP:	IP65
Finish color Availability:	Brushed Stainles steel
Certification:	cETLus
Operating Teprature:	-20°C~40°C





LuminaCast Diffuse Concrete Step Light

Product Size:

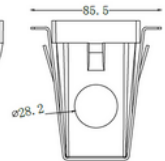
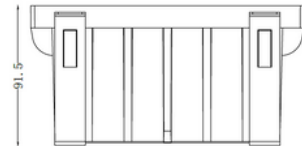
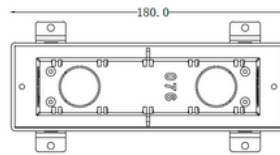
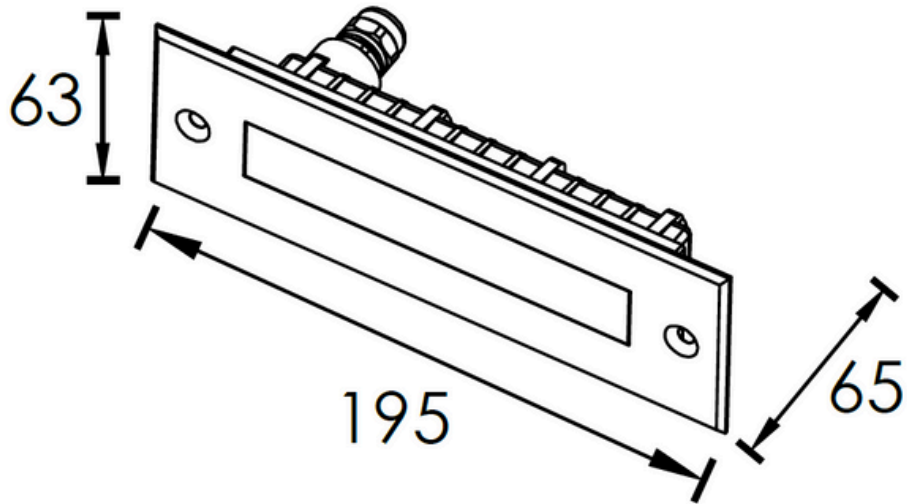



LuminaCast Diffuse Concrete Step Light

PHOTOMETRIC:

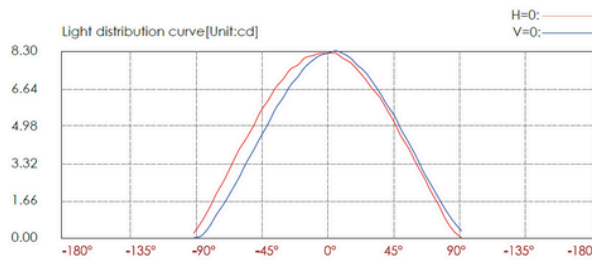
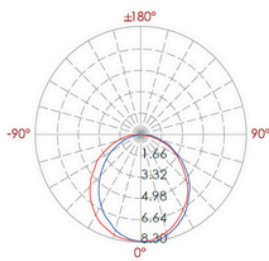

Lux distance cure

	Center beam LUX	Beam width	
		V	H
2m	2.05 LUX	5.80m	5.10m
4m	0.51 LUX	11.5m	10.1m
6m	0.23 LUX	17.3m	15.2m
8m	0.13 LUX	23.0m	20.2m
10m	0.08 LUX	28.8m	25.3m
12m	0.06 LUX	34.5m	30.3m

Ver.Spread:110.4 Horiz.Spread:103.3

