



RECESSED LED STAIR LIGHT & WALL LIGHT

Description:

The concrete pour step/wall light offers a sleek and contemporary lighting solution for concrete structures, retaining walls, steps, and stairs. With its low trim profile, it blends seamlessly with the surrounding surfaces. This fixture is highly popular due to its decent power and lumens output. Its easy installation and low maintenance make it a practical choice. The concrete pour step/wall light enhances the ambiance and safety of outdoor spaces effortlessly, adding a stylish touch to any environment.



Model: SPLD1F02243KDGKP

Optical:

CCT:	3000
LIGHT SOURCE:	12X0.2
Luminance:	CW=58 WW=55.5
LED Type:	SMD
CRI:	>80

Electrical:

Rated Power:	5.7W
Input voltage:	24VDC
Lens Degree:	120°
Operating current (MA):	24V=52

Life:

Lumen maintenance:	50,000 Hrs
Warranty:	2 YEARS

General:

IK:	10
IP:	IP65
Finish color Availability:	Brushed Stainles steel
Certification:	cETLus





RECESSED LED STAIR LIGHT & WALL LIGHT

PRODUCT SIZE:

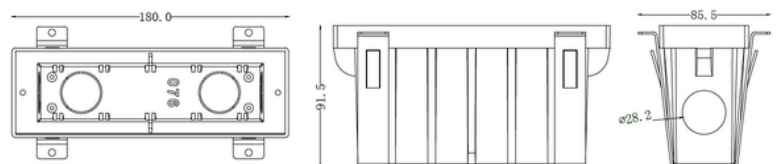
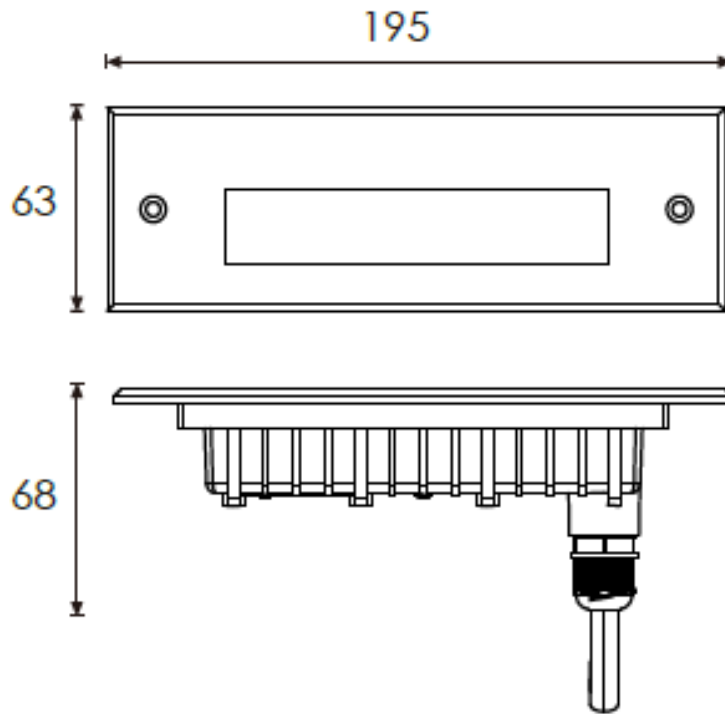



RECESSED LED STAIR LIGHT & WALL LIGHT

PHOTOMETRIC

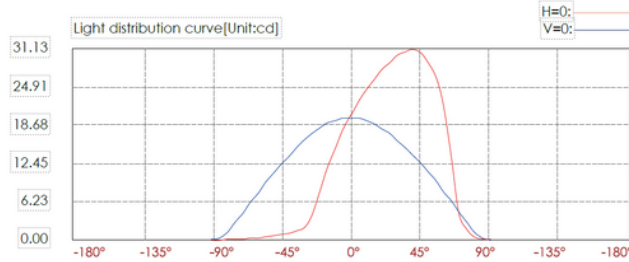
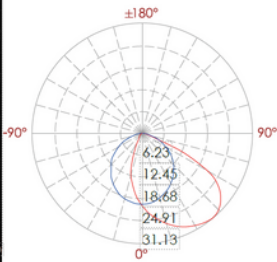

Lux distance curve

Illuminance at a distance:			
Center beam LUX	Beam width V	H	
2m	4.99 LUX	3.00m	4.70m
4m	1.25 LUX	5.90m	9.50m
6m	0.55 LUX	8.90m	14.2m
8m	0.31 LUX	11.8m	19.0m
10m	0.20 LUX	14.8m	23.7m
12m	0.14 LUX	17.7m	28.3m

Ver.Spread:72.9 Horiz.Spread:99.8

